

GENERAL DESCRIPTION

The SGM66052 is an internally compensated, 1.1MHz switching frequency, current mode, synchronous Boost switching regulator, which is capable of generating 5V output at 1A load current from a 3.3V rail. This device also has the 5.1V fixed output version.

This device turns into power-saving mode to maintain high efficiency by lowering switching frequency. With its anti-ringing circuitry damping the charge in parasitic capacitor, it reduces EMI interference significantly. Its output is disconnected by the rectifier circuit during shutdown, with no input to output leakage.

The SGM66052-5.1 is preset for outputting 5.1V, while the SGM66052-ADJ is output voltage programmable with an external resistor divider.

The device is available in a Green UTDFN-2×1.5-6L package and operates over an ambient temperature range of -40°C to +85°C.

FEATURES

- 2.2V to 5.2V Input Voltage Range
- 5.1V Fixed Output Voltage
- 6V Output Voltage Clamping
- Adjustable Output Voltage up to 5.2V
- Up to 90% Efficiency
- 20µA (TYP) Device Quiescent Current
- 1µA (MAX) Shutdown Current
- Improved Light Load Efficiency with Power-Save Mode (PSM)
- Load Disconnect during Shutdown
- Low Reverse Leakage Current when $V_{OUT} > V_{IN}$
- Over-Temperature Protection
- Available in a Green UTDFN-2×1.5-6L Package
- -40°C to +85°C Operating Temperature Range

APPLICATIONS

Single-Cell Li-Ion Powered Products
 Portable Audio Players
 Mobile Phones
 Personal Medical Devices

TYPICAL APPLICATION

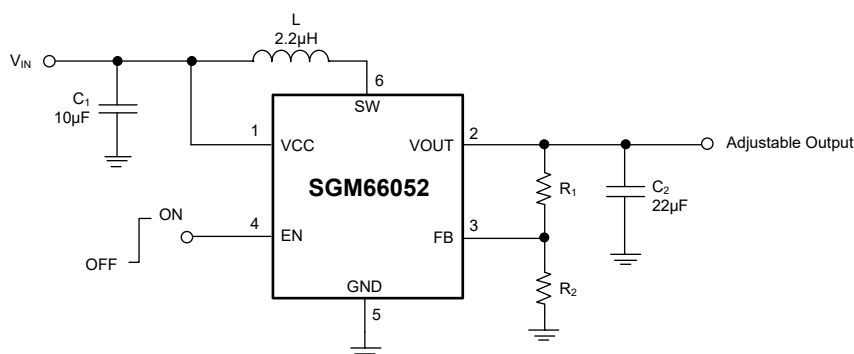

Figure 1. Typical Application Circuit

PACKAGE/ORDERING INFORMATION

MODEL	V _{OUT} (V)	PACKAGE DESCRIPTION	SPECIFIED TEMPERATURE RANGE	ORDERING NUMBER	PACKAGE MARKING	PACKING OPTION
SGM66052	5.1	UTDFN-2×1.5-6L	-40°C to +85°C	SGM66052-5.1YUDR6G/TR	G46 XXXX	Tape and Reel, 3000
	Adjustable	UTDFN-2×1.5-6L	-40°C to +85°C	SGM66052-ADJYUDR6G/TR	G48 XXXX	Tape and Reel, 3000

MARKING INFORMATION

NOTE: XXXX = Date Code.

YYY — Serial Number

XX XX

— Date Code - Week

— Date Code - Year

Green (RoHS & HSF): SG Micro Corp defines "Green" to mean Pb-Free (RoHS compatible) and free of halogen substances. If you have additional comments or questions, please contact your SGMICRO representative directly.

ABSOLUTE MAXIMUM RATINGS

Input Voltage Range on SW, V_{OUT}, V_{CC}, FB, EN
.....-0.3V to 6V

Package Thermal Resistance
UTDFN-2×1.5-6L, θ_{JA}75°C/W

Junction Temperature +150°C

Storage Temperature Range..... -65°C to +150°C

Lead Temperature (Soldering, 10s) +260°C

ESD Susceptibility

HBM..... 4000V

MM..... 400V

CDM 1000V

RECOMMENDED OPERATING CONDITIONS

Input Voltage Range 2.2V to 5.2V

Operating Temperature Range -40°C to +85°C

Operating Junction Temperature Range -40°C to +125°C

OVERSTRESS CAUTION

Stresses beyond those listed in Absolute Maximum Ratings may cause permanent damage to the device. Exposure to absolute maximum rating conditions for extended periods may affect reliability. Functional operation of the device at any conditions beyond those indicated in the Recommended Operating Conditions section is not implied.

ESD SENSITIVITY CAUTION

This integrated circuit can be damaged if ESD protections are not considered carefully. SGMICRO recommends that all integrated circuits be handled with appropriate precautions. Failure to observe proper handling and installation procedures can cause damage. ESD damage can range from subtle performance degradation to complete device failure. Precision integrated circuits may be more susceptible to damage because even small parametric changes could cause the device not to meet the published specifications.

DISCLAIMER

SG Micro Corp reserves the right to make any change in circuit design, or specifications without prior notice.

PIN CONFIGURATION

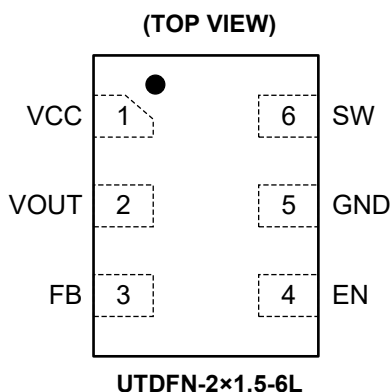

PIN DESCRIPTION

PIN	NAME	FUNCTION
1	VCC	Supply Input.
2	VOUT	Boost Converter Output. Place a storage capacitor close to this pin.
3	FB	Output Voltage Feedback Input or Internally Connected Pin. Connect to tap of external resistor divider for SGM66052-ADJ; leave it floating for SGM66052-5.1.
4	EN	Enable Input. Input logic high to enable this circuit and logic low to shut down. Do not leave this pin unconnected.
5	GND	Ground.
6	SW	Boost and Rectifying Switch Input.

ELECTRICAL CHARACTERISTICS(V_{IN} = 3.6V. Full = -40°C to +85°C, typical values are at T_A = +25°C, unless otherwise noted.)

PARAMETER	SYMBOL	CONDITIONS	TEMP	MIN	TYP	MAX	UNITS
DC/DC Stage							
Output Voltage Range	V _{OUT}	V _{IN} < 0.9V _{OUT}	Full	3.0		5.2	V
Input Voltage Range	V _{IN}		+25°C	2.2		5.2	V
Feedback Voltage	V _{FB}	SGM66052-ADJ	Full	478	495	510	mV
Switching Frequency	f		Full	850	1100	1300	kHz
Switch Current Limit	I _L		+25°C	2.15	2.7	3.25	A
Start-Up Current Limit			+25°C		500		mA
Boost Switch On-Resistance		V _{OUT} = 5.1V	+25°C		100		mΩ
Rectifying Switch On-Resistance		V _{OUT} = 5.1V	+25°C		110		mΩ
Output Voltage		SGM66052-5.1	Full	4.86	5.05	5.18	V
Line Regulation		V _{CC} = 2.7V to V _{OUT} - 0.5V	+25°C		0.5		%
Load Regulation			+25°C		0.5		%
Quiescent Current	I _Q	V _{EN} = V _{CC} = 3.6V, not switching	+25°C		20	35	μA
Shutdown Current		V _{EN} = 0V, V _{CC} = 3.6V	+25°C			1	μA
Control Stage							
EN Input Low Voltage	V _{IL}		Full			0.4	V
EN Input High Voltage	V _{IH}		Full	1.6			V
EN Input Current		Clamped on GND or VCC	Full			1	μA
Over-Temperature Protection					150		°C
Over-Temperature Hysteresis					20		°C

RECOMMENDED COMPONENTS OF TEST CIRCUITS

Component		Component	
Inductor	2.2μH/CDRH5D28RHPNP-2R2NC	Capacitor	10μF/08055C106KAT2A
			22μF/08055C226KAT2A

TYPICAL PERFORMANCE CHARACTERISTICS

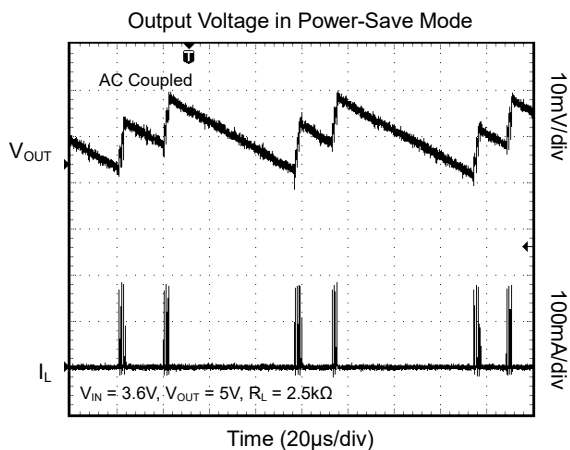
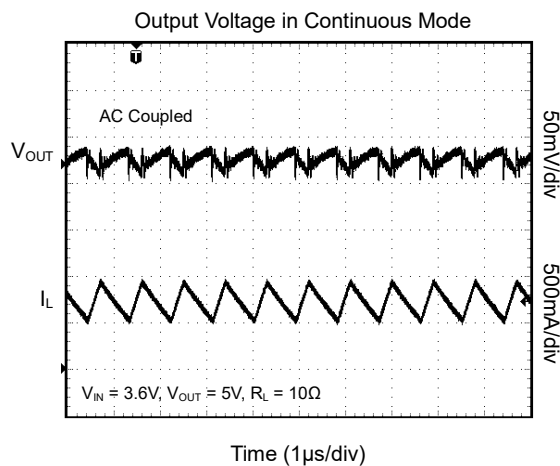
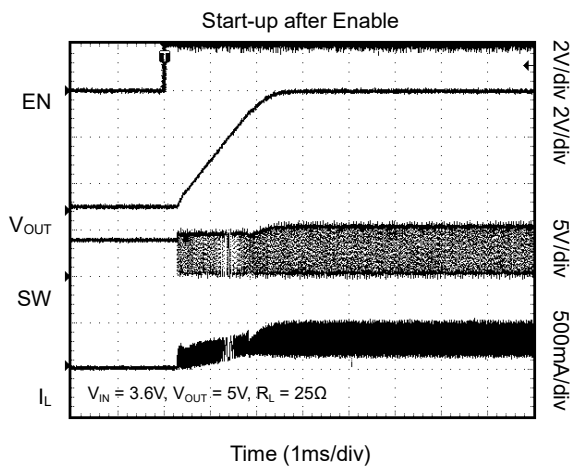
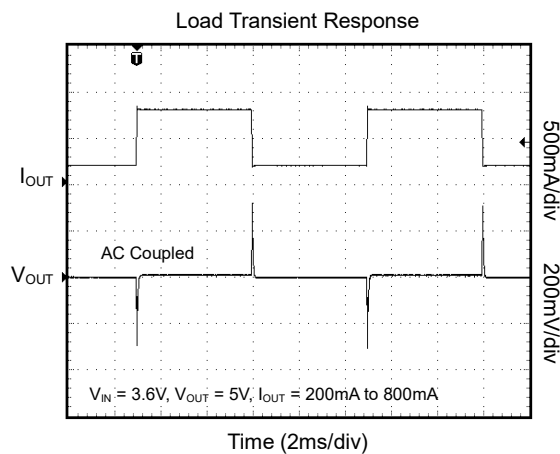
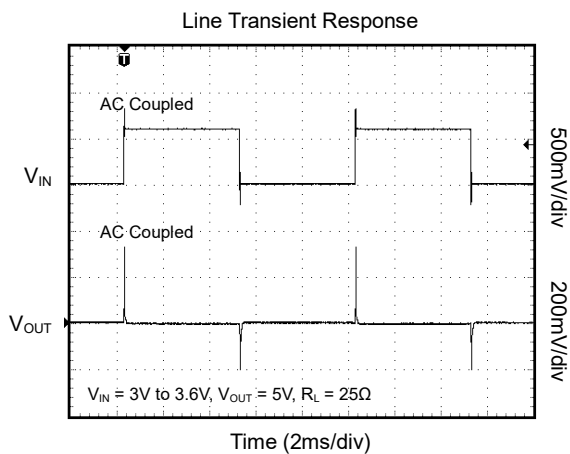

TYPICAL PERFORMANCE CHARACTERISTICS (continued)

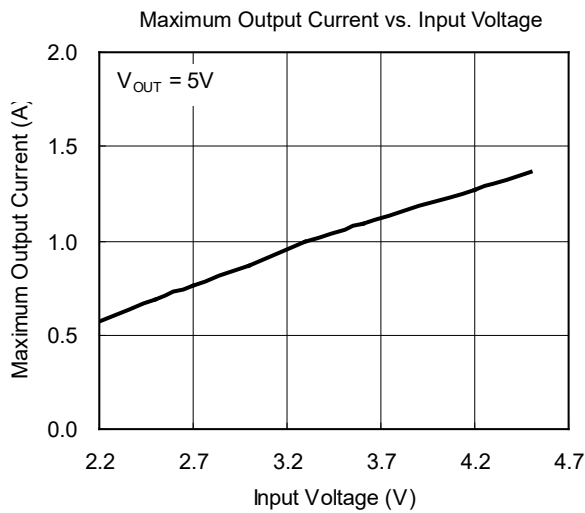
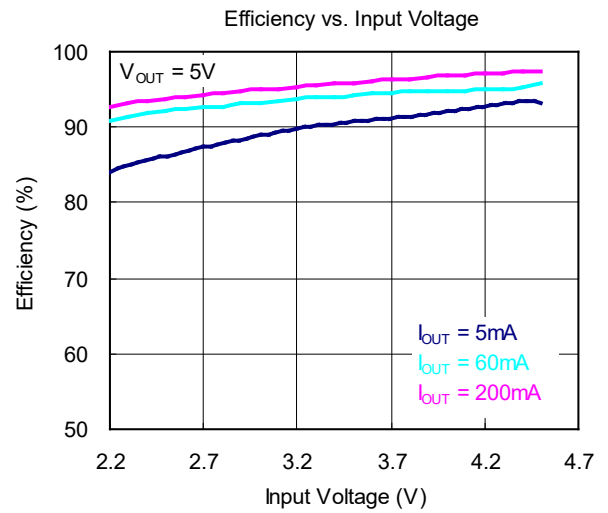
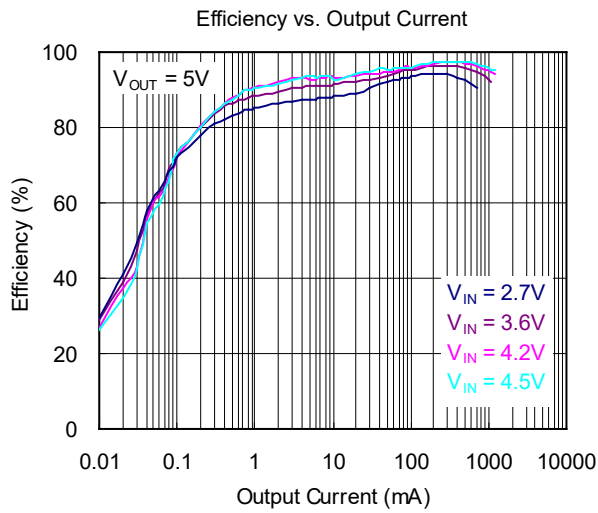
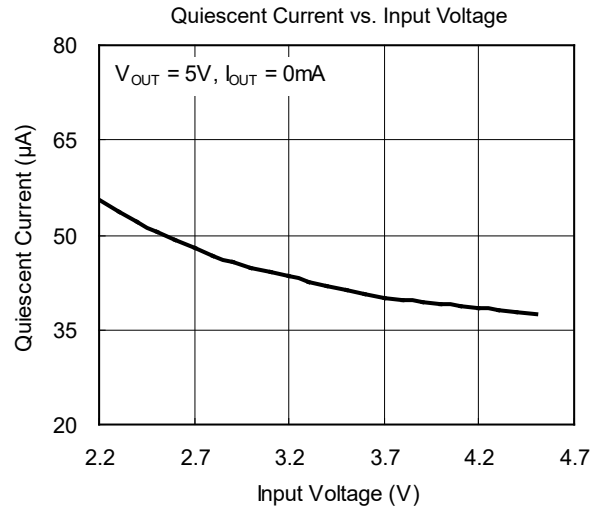
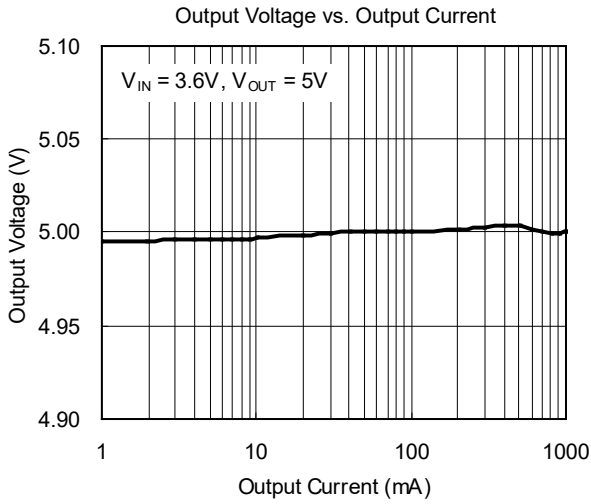

TYPICAL APPLICATION CIRCUITS

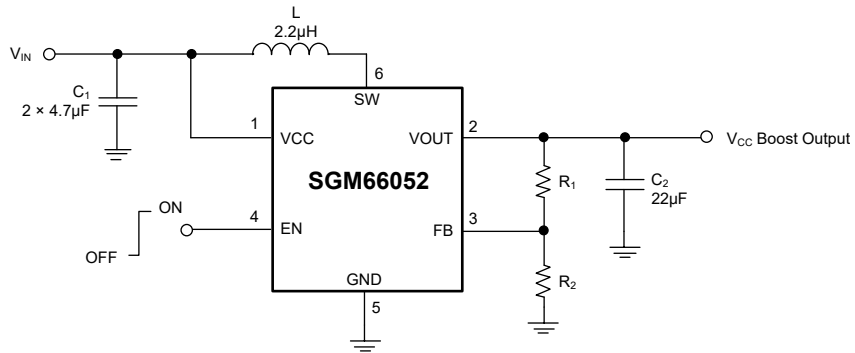

Figure 2. Power Supply Solution Having Small Total Solution Size

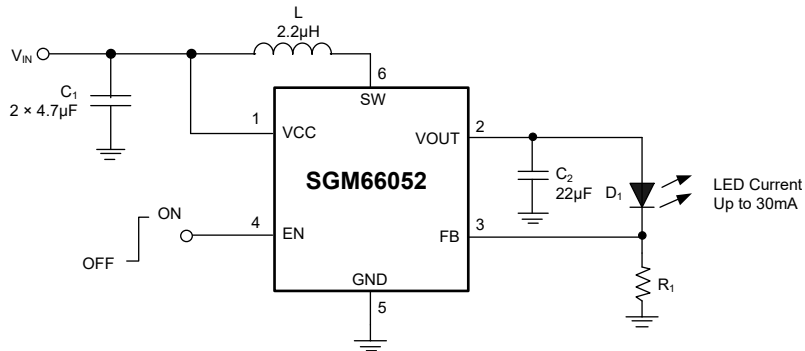

Figure 3. Circuit of Powering White LEDs in Lighting Applications

FUNCTIONAL BLOCK DIAGRAM

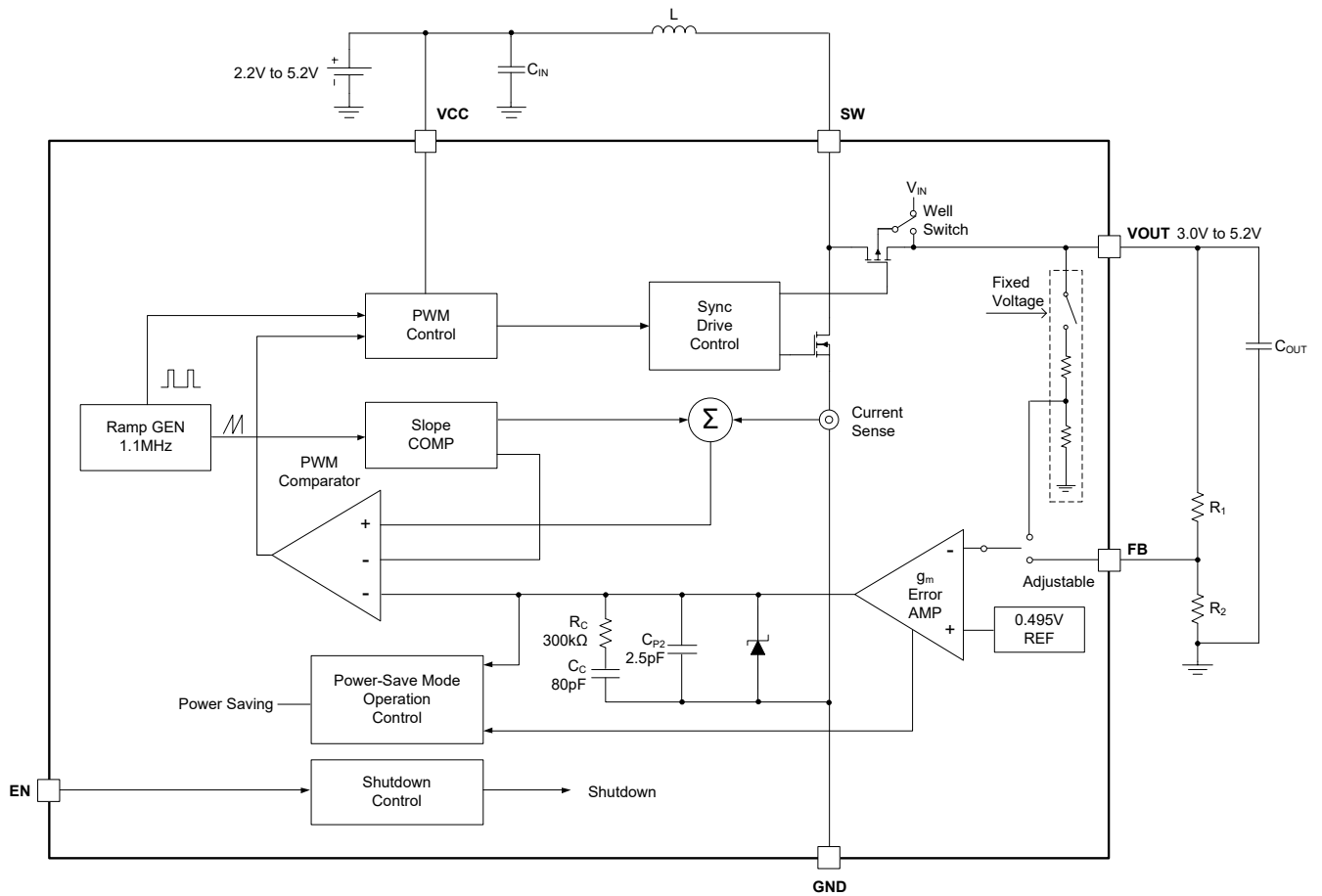

Figure 4. Block Diagram

APPLICATION INFORMATION

Design

The SGM66052 is a synchronous Boost converter capable of starting up from 2.2V input, which is suitable for majority of readily available input sources. The device is capable of providing up to 5.2V output, and the integrated power MOSFET has 2.7A (TYP) switch current limit.

Output Voltage Configuration

The SGM66052 supports output voltage up to 5.2V, and a resistor divider connected at FB pin is used to configure the output voltage. The resistive divider value is calculated via Equation 1.

$$\frac{V_{OUT} - V_{FB}}{R_1} = \frac{V_{FB}}{R_2} \quad (1)$$

For simplicity, 110kΩ is recommended for R₂. A 1MΩ resistor for R₁ configures the output voltage to 5V.

Inductor Selection

Inductor is an essential element for today's DC/DC switch mode power supplies regardless of topology. Inductor serves as the energy storage element for power conversion. Inductance and inductor's saturation current are two most important criterions for inductor selection. For general rule of thumb, the selected inductance should provide a peak to peak ripple current that is around 30% of the average inductor current at full load and nominal input voltage. The average inductor current for a Boost converter is the input current. Equation 2 shows the calculation of inductance selection, where f is the switching frequency, ΔI_L is the inductor ripple current.

$$L = \frac{V_{CC}}{\Delta I_L \times f_{SW}} \times \left(1 - \frac{V_{IN}}{V_O} \right) \quad (2)$$

The selected inductor should have a saturation current rating higher than the 2.7A current limit of SGM66052.

Lastly, the inductor affects the close loop response of the DC/DC converter. The SGM66052 is an internally

compensated device with the loop response optimized for inductor in the range of 2.2μH to 10μH.

Input Capacitor

Boost converter's input capacitor sees continuous current throughout the entire switching cycle. A 10μF ceramic capacitor is recommended to place as close as possible between the VCC pin and GND pin of SGM66052. For the applications where the SGM66052 is located far away from the input source, a 47μF or higher capacitance capacitor is recommended to damp the wiring harness's inductance.

Output Capacitor

The output capacitors of Boost converter dictate the output voltage ripple and load transient response. Equation 3 is used to estimate the necessary capacitance to achieve desired output voltage ripple. Where ΔV is the maximum allowed ripple.

$$C_{MIN} = \frac{I_O \times (V_{OUT} - V_{CC})}{f \times \Delta V \times V_{OUT}} \quad (3)$$

Again, the SGM66052 is an internally compensated device. The loop response is optimized for capacitor in the range of 4.7μF to 22μF. Due to the DC bias nature of ceramic capacitors, care should be taken by verifying manufacture's datasheet to ensure enough effective capacitance at desired output voltage.

Layout Guidelines

In addition to component selection, layout is a critical step to ensure the performance of any switch mode power supplies. Poor layout could result in system instability, EMI failure, and device damage. Thus, place the inductor, input and output capacitors as close to the IC as possible, and use wide and short traces for current carrying traces to minimize PCB inductance.

For Boost converter, the output capacitor's current loop from VOUT pin back to the GND pin of the device should be as small as possible.

REVISION HISTORY

NOTE: Page numbers for previous revisions may differ from page numbers in the current version.

MAY 2022 – REV.A.2 to REV.A.3	Page
Updated Application Information section.....	9
<hr/>	
NOVEMBER 2021 – REV.A.1 to REV.A.2	Page
Added the Figure 2 Block Diagram and updated the Programming Output Voltage sections.....	8, 9
<hr/>	
FEBRUARY 2021 – REV.A to REV.A.1	Page
Updated Features and Recommended Operating Conditions	1, 2
<hr/>	
Changes from Original (MARCH 2016) to REV.A	Page
Changed from product preview to production data.....	All

PACKAGE OUTLINE DIMENSIONS

UTDFN-2x1.5-6L

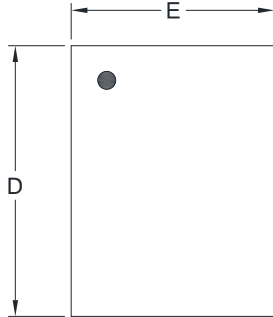

TOP VIEW

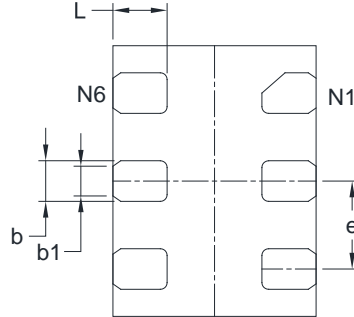

BOTTOM VIEW

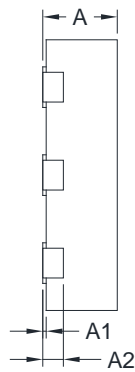

SIDE VIEW

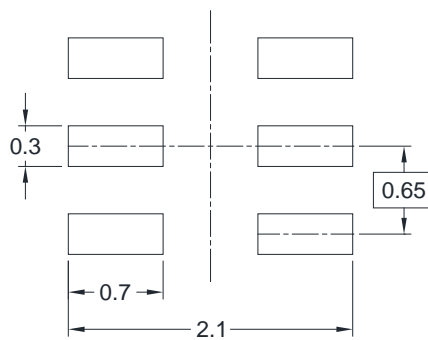

RECOMMENDED LAND PATTERN (Unit: mm)

Symbol	Dimensions In Millimeters		Dimensions In Inches	
	MIN	MAX	MIN	MAX
A	0.500	0.600	0.020	0.024
A1	0.000	0.050	0.000	0.002
A2	0.152 REF		0.006 REF	
D	1.900	2.100	0.075	0.083
E	1.400	1.600	0.055	0.063
b	0.250	0.350	0.010	0.014
b1	0.220 REF		0.009 REF	
e	0.650 BSC		0.026 BSC	
L	0.324	0.476	0.013	0.019

NOTE: This drawing is subject to change without notice.

PACKAGE INFORMATION

TAPE AND REEL INFORMATION

REEL DIMENSIONS



TAPE DIMENSIONS



NOTE: The picture is only for reference. Please make the object as the standard.

KEY PARAMETER LIST OF TAPE AND REEL

Package Type	Reel Diameter	Reel Width W1 (mm)	A0 (mm)	B0 (mm)	K0 (mm)	P0 (mm)	P1 (mm)	P2 (mm)	W (mm)	Pin1 Quadrant
UTDFN-2×1.5-6L	7"	9.5	1.75	2.25	0.65	4.0	4.0	2.0	8.0	Q1

000001

PACKAGE INFORMATION

CARTON BOX DIMENSIONS



NOTE: The picture is only for reference. Please make the object as the standard.

KEY PARAMETER LIST OF CARTON BOX

Reel Type	Length (mm)	Width (mm)	Height (mm)	Pizza/Carton
7" (Option)	368	227	224	8
7"	442	410	224	18

DD0002